

## IGLOO DOUBLE EVAPORATOR - DAV EQUIPMENTS

2 Drafts

D3076

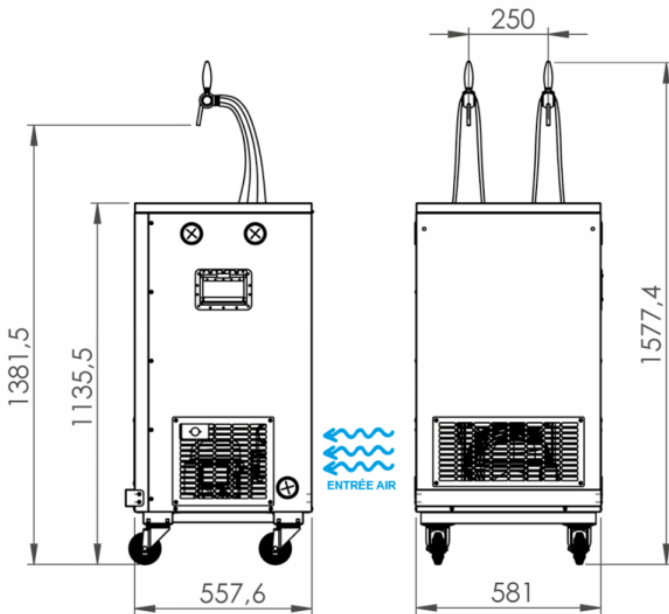

MADE IN FRANCE



Easily transportable: reinforced handles and wheels  
All in stainless steel  
Suitable for major events  
Optimum beer service quality  
Integrated expansion valve and drain valve  
Designed and manufactured in France by DAV EQUIPMENTS

DAV EQUIPMENTS has been an expert in the development and manufacture of beverage cooling solutions for 60 years and offers you, through a proven process, a range of mobile furniture that ensures optimum beer service quality. We guarantee you the freshness of your beers throughout your events: festivals, exhibitions, events, concerts, music festivals... The double evaporator Igloo will ensure a flow rate on 2 nozzles of 295 l/h ( $\Delta T$  15).



## Technical Specifications

NUMBER OF MAX. DRAFTS	2T
HOURLY FLOW ( $\Delta T$ 15) L/H	295
COMPRESSOR POWER (HP)	3/4
WEIGHT (KG)	87
TANK CAPACITY (L)	85
WEIGHT OF THE ICE BANK (KG)	40
MEASUREMENT DIMENSIONS (MM)	W.581 x D.558 x H.1578
THERMOSTAT (TEMPÉRATURE DE LA RÉSERVE FROID)	mechanical
MAX LENGTH OF SERPENTINES (M)	2x30
REFRIGERANT FLUID	R134A
EVAPORATOR	copper
BOWL MATERIAL	Polystyrene Shock
FOAM MATERIAL INSULATION	Polyurethane
GROUNDING OUTLET	Mandatory
MAX POWER	918

To discover more about this product, scan this QR code.

