

## PICCOLO

1 draft

D3047DET



The compact PICCOLO will be easy to transport. It will find its place easily thanks to its small size. All in resin and fixed molded tray, it will ensure you robustness. It will be particularly suitable for serving your drinks at your events: up to 100 l/h ( $\Delta T$  15). Integrated regulator and drain valve.

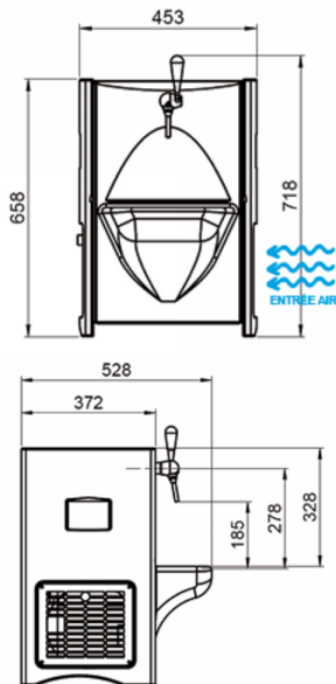

## Technical Specifications

NUMBER OF MAX. DRAFTS	1T
HOURLY FLOW ( $\Delta T$ 15) L/H	64
COMPRESSOR POWER (HP)	1/4
WEIGHT (KG)	35
TANK CAPACITY (L)	18
WEIGHT OF THE ICE BANK (KG)	6
MEASUREMENT DIMENSIONS (MM)	L.453 x d.528 x h. 718
THERMOSTAT (TEMPÉRATURE DE LA RÉSERVE FROID)	mechanical
MAX LENGTH OF SERPENTINES (M)	22 (7×8)
REFRIGERANT FLUID	R290a
EVAPORATOR	copper
BOWL MATERIAL	Polyethylene
FOAM MATERIAL INSULATION	Polyurethane
GROUNDING OUTLET	Mandatory
MAX POWER	308

To discover more about this product, scan this QR code.

