

WINTERHALTER dishwasher

integrated drain pump

R4090



Integrated washing and rinsing product dispensers.

Fast cycle time

Powerful

Cleanliness and impeccable hygiene

Single or three-phase /

It can be adapted to all institutions

Easy to use - one button

In the middle of a rush, this dishwasher provides very fast performance: no more wiping for your staff. To meet the highest standards of cleanliness and hygiene: WinterHalter professional dishwashers are suitable for many sectors, including cafés, hotels and restaurants. High quality and reliability.

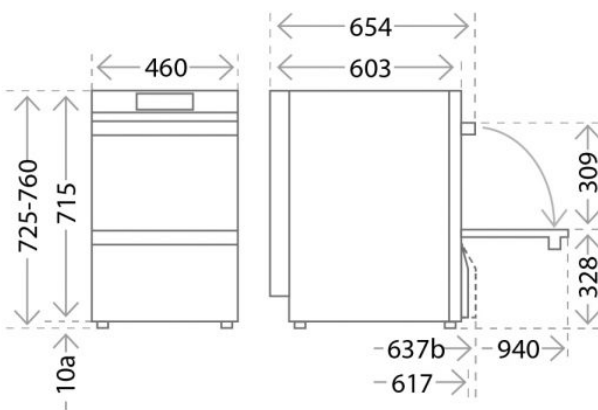

Technical Specifications

MEASUREMENT DIMENSIONS (MM)	
BODYWORK	
GLASS PASSAGE HEIGHT (MM)	309
DURATION OF CYCLES (SC)	
DRAIN PUMP	included
DOSE RINSE PRODUCT	
WASHING PRODUCT DOSER	
TANK CAPACITY (L)	
CONSO. WATER PER CYCLE (L)	
SOUND LEVEL (DB)	55
CART NUMBER	
CART DIMENSION (MM)	400 x 400
WASHING TEMPERATURE (°C)	
RINCING TEMPERATURE (°C)	
TEMPÉRATURE ENTRÉ EAU (°C)	
HARDNESS WATER SUPPLY. (°DF)	
WEIGHT (KG)	59
POWER SUPPLY	400 volts modulable 220 – 240 V / 50 Hz
POWER (W)	
GROUNDING OUTLET	Mandatory
PROTECTION FACTOR	

To discover more about this product, scan this QR code.

